

T50P PIF Non-return valves

- Port size:
O/D tube 4 ... 12 mm
- Allow free flow in one direction only
- Simple reliable design
- Low weight
- Low cracking pressure
- High operating pressure



Technical features

Medium:
Compressed air, filtered, lubricated or non-lubricated, vacuum

Operation:
Non-return valve

Operating pressure:
-0,9 ... 16 bar (-13 ... 232 psi)

Cracking pressure:
0,03 ... 0,05 bar (0,4 ... 0,7 psi)

O/D tube:
ø 4, 6, 8, 10, 12 mm

Ambient/Media temperature:
-20 ... +80°C max. (-4 ... +176°F)
Air supply must be dry enough to avoid ice formation at temperatures below +2°C (+35°F).

Materials:
Body: Aluminium
Grab ring: Nickel plated brass
'O'-ring: NBR

Tubing types:
PA 11 or 12, PUR and other plasticised or unplasticised tubing which conforms to the tolerances specified in BS 5409, Part 1, 1976, light and normal duty, DIN 73378, DIN 74234, NFE 49-100

Technical data

Symbol	Ø Tube (mm)	Flow factor		Cv	Kv *2)	Flow at 6 » 5 bar (l/min)	Weight (kg)	Model
		C *1)	b *3)					
	4	0,4	0,23	0,1	0,09	96	0,010	T50P0004
	6	1,45	0,36	0,36	0,31	349	0,016	T50P0006
	8	2,9	0,3	0,7	0,62	699	0,022	T50P0008
	10	5,1	0,35	1,25	1,09	1229	0,048	T50P0010
	12	8,4	0,42	2,1	1,79	2024	0,064	T50P0012

*1) Measured in dm³/(s.bar)

*2) Measured in m³/h

*3) b = critical pressure ratio

Option selector

T50P00★★

Tube size (mm)	Substitute
4	04
6	06
8	08
10	10
12	12

Method of assembly

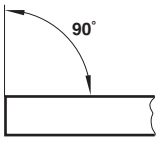
- 

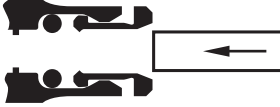
1. Ensure that the end of the tube is cut square and is free from burrs.
- 

2. Push the tube through the collet into the fitting.
- 

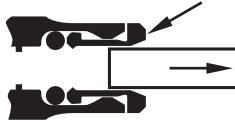
3. Continue pushing the tube through the 'O'-ring until it bottoms on the tube stop then pull back.
- 

4. To disconnect push the tube into the fitting, hold down the collet and withdraw the tube.

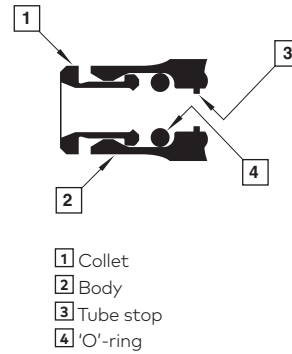

Technical data

$\varnothing A$ O/D tube	$\varnothing S$	$\varnothing T$ *1)	V	$\varnothing K$
4	2,8	14	7,5	10
5	3,4	15	10	11
6	4,4	15,5	11	12
8	6	16,5	13	14
10	7,6	21	14,5	17
12	9,6	24,5	18	20,5

*1) Dimensions here and in the individual tables refer to the collet being in the 'IN' position.

Dimensions

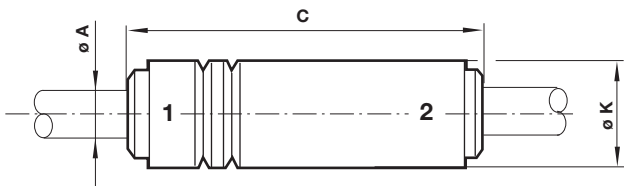

$\varnothing A$	C	$\varnothing K$	Model
4	49	11	T50P0004
6	56,5	13	T50P0006
8	61	15	T50P0008
10	77,5	20	T50P0010
12	88,5	22	T50P0012

Warning

These products are intended for use in industrial compressed air systems only. Do not use these products where pressures and temperatures can exceed those listed under »**Technical features/data**«. Before using these products with fluids other than those specified, for non-industrial applications, life-support systems or other applications not within published specifications, consult Norgren Ltd.

Through misuse, age, or malfunction, components used in fluid power systems can fail in various modes.

The system designer is warned to consider the failure modes of all component parts used in fluid power systems and to provide adequate safeguards to prevent personal injury or damage to equipment in the event of such failure.

System designers must provide a warning to end users in the system instructional manual if protection against a failure mode cannot be adequately provided.

System designers and end users are cautioned to review specific warnings found in instruction sheets packed and shipped with these products.

Dimensions in mm
Projection/First angle

